

STRUCTURE #13 SECTION
SCALE: 1" = 2'

- NOTES:
1. CMP DENOTES CORRUGATED METAL PIPE. PIPE SHALL HAVE ASPHALTIC COATING ON BOTH OUTSIDE AND INSIDE FACES PER MSHA SPECS. PIPE SHALL BE MOVED WITH THE USE OF SLINGS. DO NOT DRAG COATED PIPE.
 2. NO FIELD WELDING WILL BE ALLOWED FOR CMP DETENTION PIPE UNLESS APPROVED BY INSPECTOR. ALL CONSTRUCTION PROCEDURES TO BE IN ACCORDANCE WITH PRINCE GEORGES' COUNTY AND MSHA SPECIFICATIONS. ENGINEER TO BE NOTIFIED FOR INSPECTION 2-3 DAYS PRIOR TO BACKFILLING. THIS UNDERGROUND DETENTION FACILITY WILL BE PRIVATELY MAINTAINED.

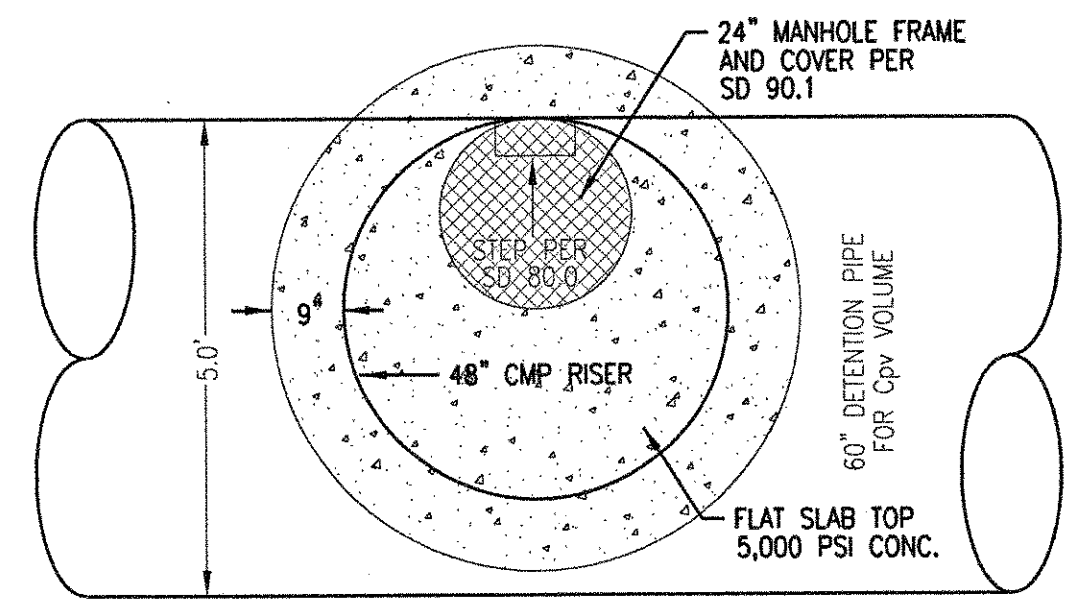

TYPICAL RISER DETAIL
SCALE: 1" = 2'

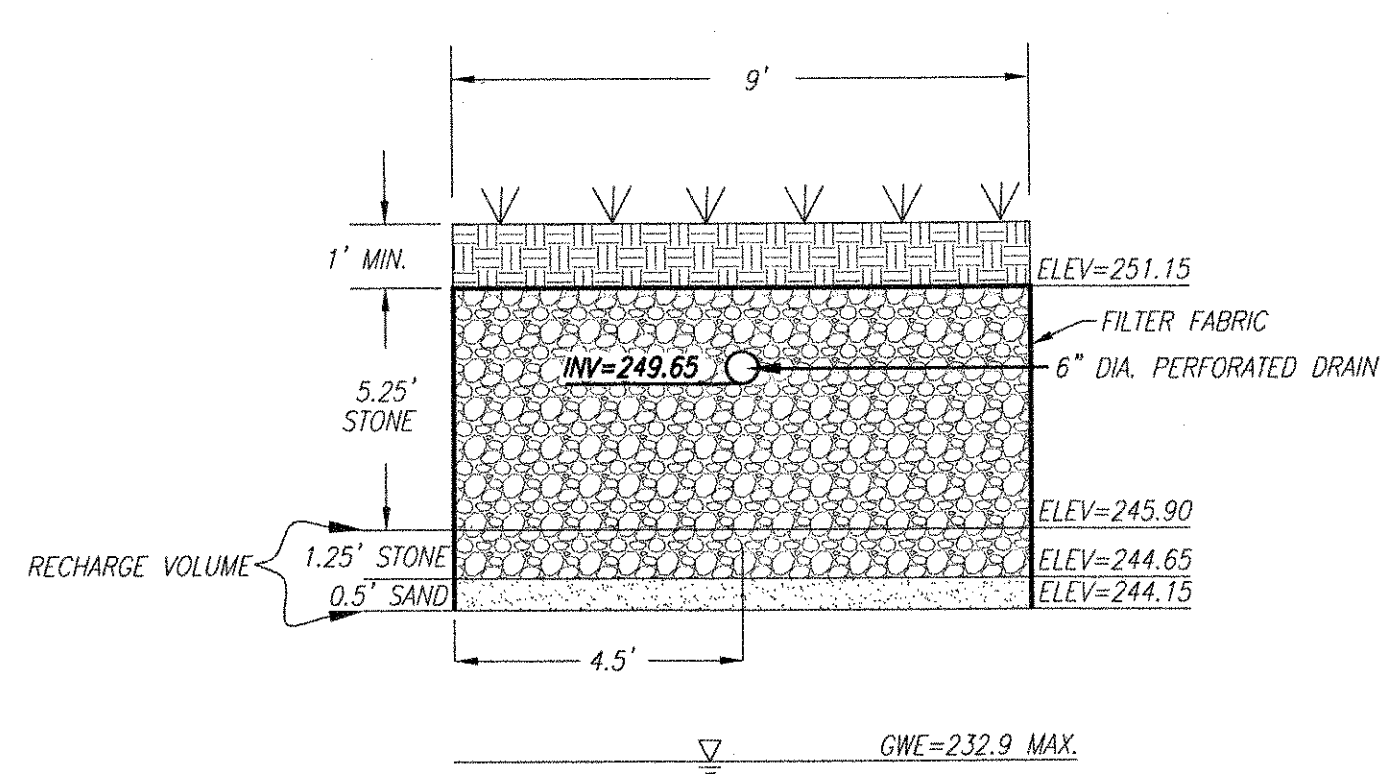

INFILTRATION TRENCH CROSS-SECTION
N.T.S.

1. SAND AND GRAVEL SHALL MEET STATE AND COUNTY STANDARDS AND SPECIFICATIONS.
2. UPSTREAM DRAINAGE AREAS MUST BE STABILIZED PRIOR TO INSTALLING TRENCH.
3. BOTTOM OF TRENCH SHALL BE LEFT IN A ROUGHENED CONDITION TO HELP FACILITATE INFILTRATION.
4. REFER TO MATERIAL AND INSTALLATION SPECIFICATIONS FOR ADDITIONAL INFORMATION.
5. NO GROUNDWATER OR POOLS WILL BE DISCHARGED TO THE BMP.
6. CONTRACTOR SHALL PROVIDE CERTIFICATIONS OF ALL FILTER MATERIALS FOR REVIEW AND APPROVAL BY DESIGN ENGINEER.
7. ALL DEBRIS IS TO BE KEPT OUT OF FACILITY DURING AND AFTER CONSTRUCTION.
8. NO PERFORMANCES OUTSIDE THE TRENCH BOUNDARIES.

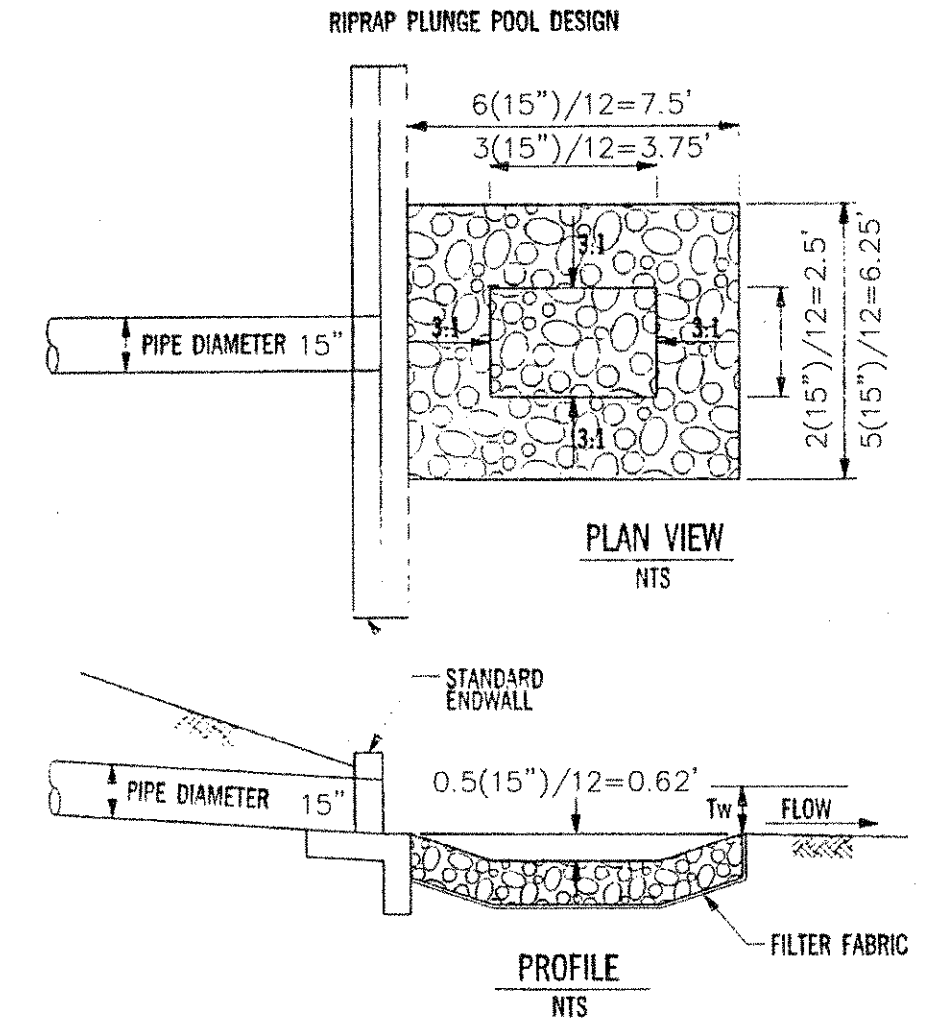

$$RIPRAP\ d_{50} = \frac{0.0125Q}{\sqrt{h}} \left(\frac{L}{D} \right)^{1.333}$$

$$= 0.0125(1.25) \sqrt{2} \left(\frac{7.08}{1.25} \right)^{1.333} \left(\frac{1.25}{0.10} \right)^{1.333}$$
 WHERE
 D = PIPE DIAMETER (ft) = 1.25 ft USE MSHA CLASS 1 RIP-RAP
 Tw = TAILWATER DEPTH (ft) = 1.25 ft
 Q = DESIGN STORM DISCHARGE (cfs) = 7.08 cfs

NOTES:

1. MINIMUM RIPRAP SIZE SHALL BE $d_{50} = 6"$ FOR STORM DRAIN OUTFALLS, AND $d_{50} = 9.5"$ FOR 18378 POND OUTFALLS
2. MAXIMUM PLUNGE POOL DEPTH SHALL BE 3'.

Cpv ORIFICE COMPUTATIONS
24-hr Drawdown

Detention Pipe	
Cpv Storage Volume =	5,969 cf
Cpv Storage Elevation =	251.40 STR#12 OUT INV
Cpv Orifice Invert =	245.59
$C_c = A(64.4^2 h^3)^{0.5}$	
$C_c =$	0.60
$A = [(d)^2] \pi / 4$	
$h =$ Storage Elevation - CL Elevation	
$Q =$ Storage Volume / [24hr(60min/hr)(60sec/min)]	
therefore:	
$d = 4Q / C_c \pi^{0.5} (64.4^2 h^3)^{0.5}$	
$Q =$	0.07 cfs
$h =$	5.61 ft (approx)
$C_c =$	0.60
$d =$	0.09 ft
or	1.05 in
use	1.05 in 1-3/64"
Check	
$t =$ Storage Volume	
$t = 3600c / A(64.4^2 h^3)^{0.5}$	
$C_c =$	0.60
$A =$	0.0060 sf
$h =$	5.77 ft
$t =$	24.0 hr > 24 hr minimum

PIPE STORAGE VOLUME:

ELEV. (FEET)	DEPTH (FEET)	PIPE END AREA (SQ.FT.)	PIPE LENGTH (FEET)	MAN-HOLE VOLUME (CU.FT.)	TOTAL VOLUME (CU.FT.)
[A]	[B]	[C]	[D]	[E]	[C][D]+[E]
245.55	0.00	0.00	304.0	0	0
246.55	1.00	2.80	304.0	0.0	850
247.55	2.00	7.33	304.0	0.0	2230
248.55	3.00	12.30	304.0	0.0	3739
249.55	4.00	16.84	304.0	0.0	5119
250.55	5.00	19.64	304.0	0.0	5969

VOLUME PROVIDED

INFILTRATION TRENCH SIZING

$WQV = 2,949$ C.F. (INCLUDES REV)
 $f = (1.02 \text{ IN/HR} + 0.52 \text{ IN/HR}) / 2 = 0.77 \text{ IN/HR}$ (AVERAGE OF SOILS REPORT VALUES)
 $T_s = 48 \text{ HR}$
 $n = 0.40$
 $d(\text{MAX}) = f(T_s) / n = (0.77)(48) / (0.40) = 92.4 \text{ IN} = 7.7 \text{ FT}$
 $d(t) = \text{USE } 7 \text{ FT}$
 $T = 2 \text{ HR}$
 $A(t) = WQV / [(n)(d)(T)] = (2,949) / [(0.40)(7)(2)] = 1,007 \text{ S.F.}$
 PROPOSED TRENCH DIMENSIONS: L=112', W=9'
 $A = L \times W = (112)(9) = 1,008 \text{ S.F.} > 1,007 \text{ S.F. MIN.}$

Rev STORAGE VOLUME DEPTH
 REQUIRED Rev VOLUME = 680 CF
 VOID RATIO OF GRAVEL = 0.40
 DEPTH OF GRAVEL BELOW PERFORATED PIPES = Rev/0.40(A)
 DEPTH = $[680 / 0.40(1,008)] = 1.69 \text{ FEET}$
 USE 1.75 FEET OR 21 INCHES: $(1.75)(0.40)(1,008) = 706 \text{ CF} > 680 \text{ CF REQUIRED}$

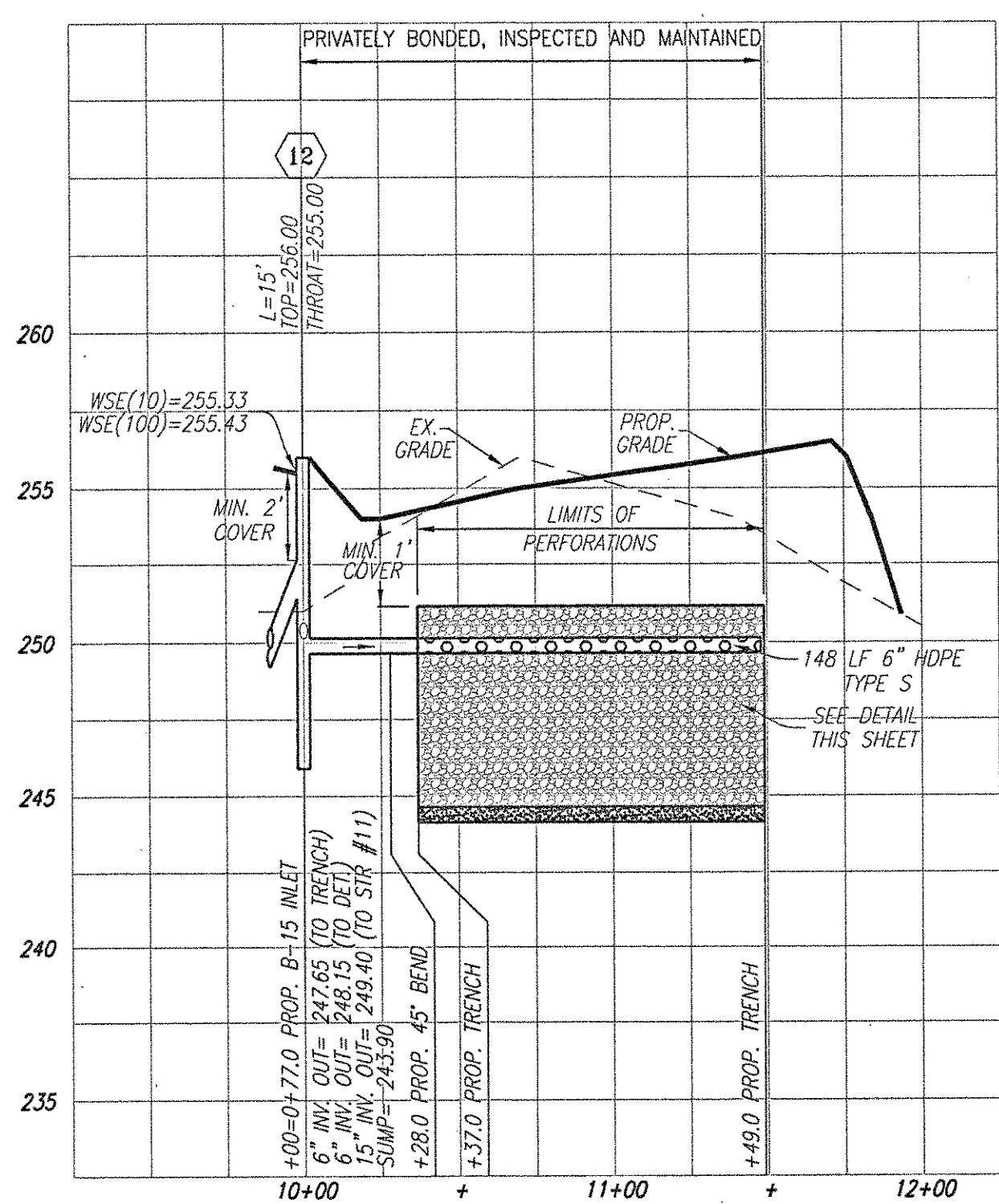

STORM DRAIN PROFILE
SCALE: 1" = 50' HORIZONTAL
1" = 5' VERTICAL

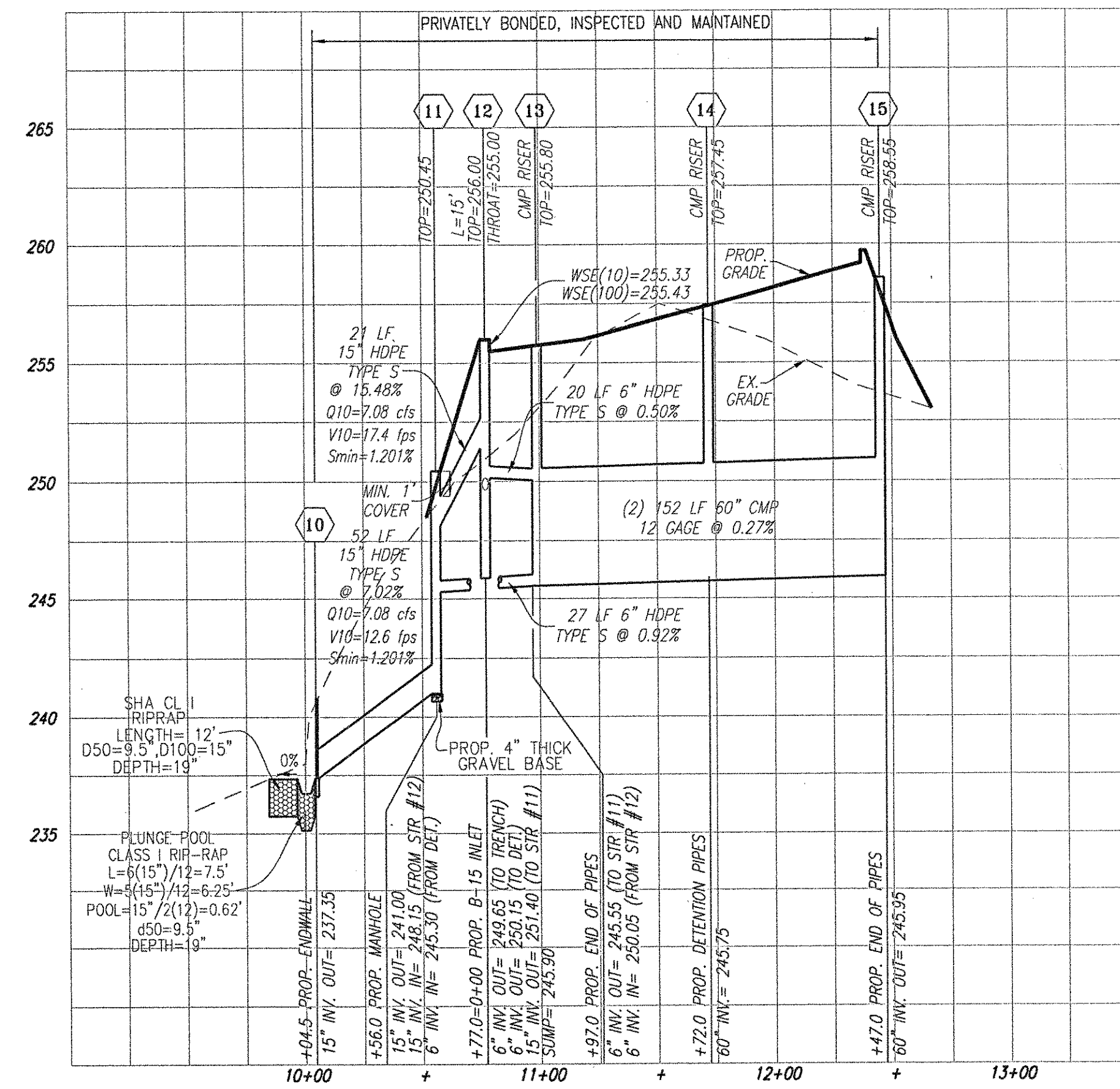

STORM DRAIN PROFILE
SCALE: 1" = 50' HORIZONTAL
1" = 5' VERTICAL

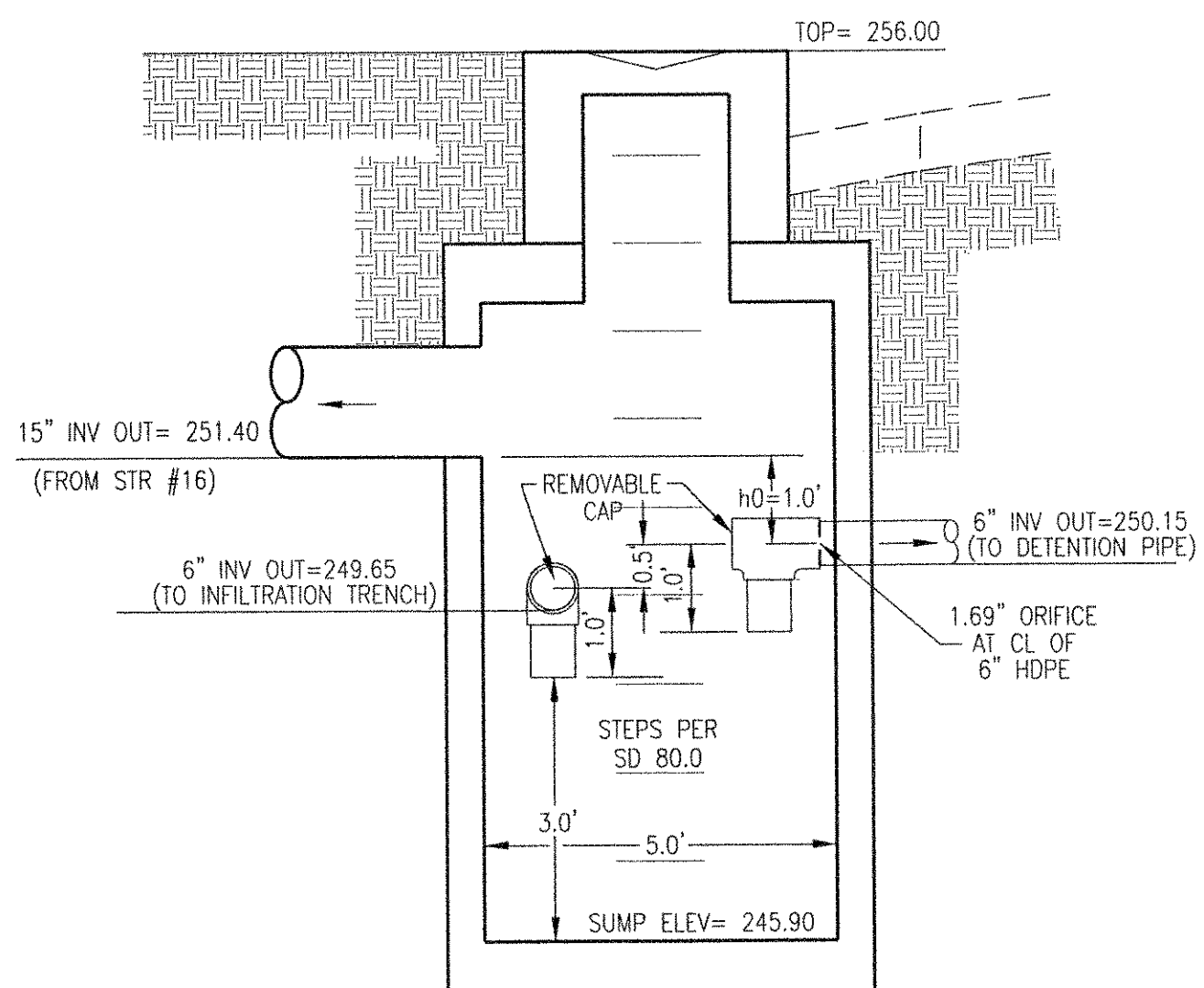

STRUCTURE #12 DETAIL
NO SCALE

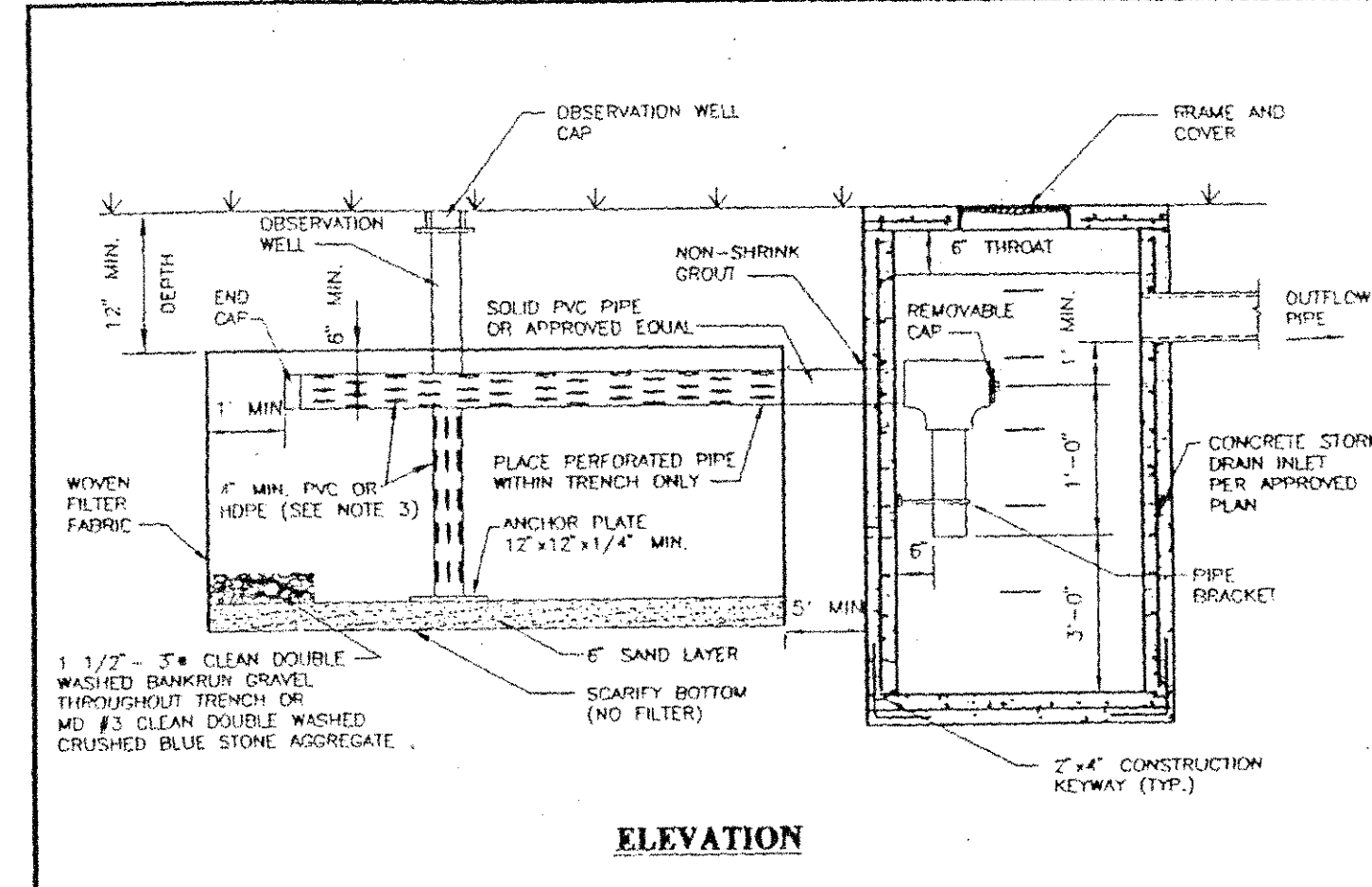

ELEVATION

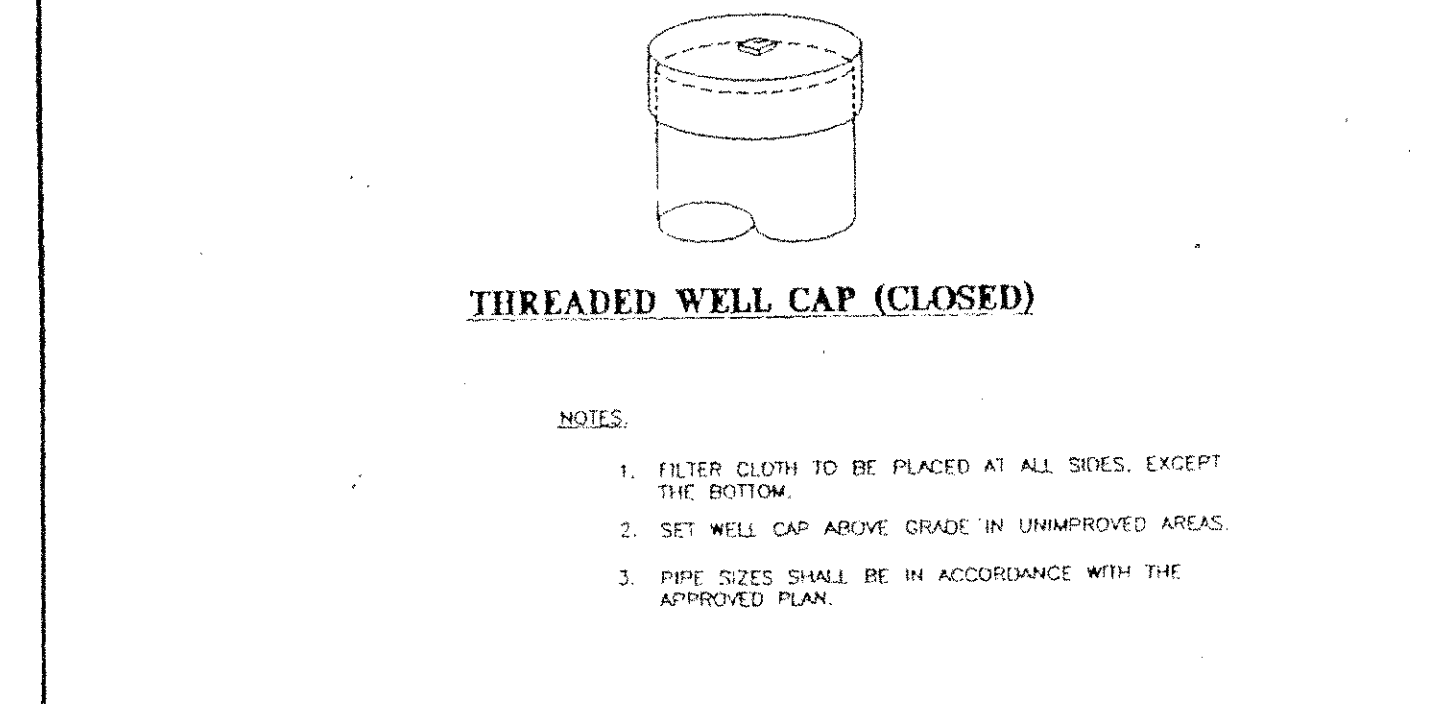

THREADED WELL CAP (CLOSED)

- NOTES:
1. FILTER CLOTH TO BE PLACED AT ALL SIDES, EXCEPT THE BOTTOM.
 2. SET WELL CAP ABOVE GRADE IN UNIMPROVED AREAS.
 3. PIPE SIZES SHALL BE IN ACCORDANCE WITH THE APPROVED PLAN.

CAUTION - NOTICE TO CONTRACTOR

THE CONTRACTOR IS SPECIFICALLY CAUTIONED THAT THE LOCATION AND/OR ELEVATION OF EXISTING UTILITIES AS SHOWN ON THESE PLANS IS BASED ON RECORDS OF THE VARIOUS UTILITY COMPANIES AND, WHERE POSSIBLE, MEASUREMENTS TAKEN IN THE FIELD. THE INFORMATION IS NOT TO BE RELIED ON AS BEING EXACT OR COMPLETE. THE CONTRACTOR MUST CALL THE APPROPRIATE UTILITY COMPANY AT LEAST 48 HOURS BEFORE ANY EXCAVATION TO REQUEST EXACT FIELD LOCATION OF UTILITIES. IT SHALL BE THE RESPONSIBILITY OF THE CONTRACTOR TO RELOCATE ALL EXISTING UTILITIES WHICH CONFLICT WITH THE PROPOSED IMPROVEMENTS SHOWN ON THE PLANS AND TO VERIFY THE EXACT LOCATION OF ALL EXISTING UTILITIES PRIOR TO COMMENCEMENT OF CONSTRUCTION ACTIVITIES.

SD#	1837-2005-01
PROJECT NAME	BETH SHALOM AME ZION CHURCH
PRINCE GEORGE'S COUNTY, MD DEPARTMENT OF ENVIRONMENTAL RESOURCES	
APPROVED FOR STORMWATER MANAGEMENT AND STORM DRAIN ONLY	
T. Ding	5/1/07
DATE	

REVISIONS:

3/31/07 SHIFT PROP. IMP'S
TO EAST, REDUCE I6 FROM
1.18 TO 1.06 AC. REDUCE DET.
PIPE FROM 8" TO 5" DIA.

WARDER
Your Church Builder
Phone: (301) 868-5900
Toll Free: (800) 868-7266
Fax: (301) 868-3740
www.wardergroup.com

WE Inc.
Williams Enterprises Incorporated
18 Mosby Lane Stafford, Virginia 22556
540-286-3710 and 540-286-0345 Fax
weinc@hughes.net

DATE: MARCH 2007
SCALE: N/A
DRAWING NAME:
19D09-SWM2-REV5

PROFILES AND DETAILS
BETH SHALOM AME
ZION CHURCH
6TH ELECTION DISTRICT
PRINCE GEORGE'S COUNTY, MARYLAND

SHEET
SD 3
OF
3
FILE No.
MDPG-19D09-01